



# **Studies of A356 Aluminum Alloy for Sand Mould Casting Gating System**

**Kishor Purushottam Kolhe<sup>a\*⊙</sup> and Abebe Halefom Gebrekidan<sup>b#</sup>**

<sup>a</sup> Department of Industrial Engineering, Woldia Institute of Technology, Woldia University, Ethiopia.  
<sup>b</sup> Woldia Institute of Technology, Ethiopia.

## **Authors' contributions**

*This work was carried out in collaboration between both authors. Both authors read and approved the final manuscript.*

## **Article Information**

DOI: 10.9734/JERR/2022/v22i917558

## **Open Peer Review History:**

This journal follows the Advanced Open Peer Review policy. Identity of the Reviewers, Editor(s) and additional Reviewers, peer review comments, different versions of the manuscript, comments of the editors, etc are available here: <https://www.sdiarticle5.com/review-history/86614>

**Original Research Article**

**Received 22 February 2022**  
**Accepted 27 April 2022**  
**Published 03 June 2022**

## **ABSTRACT**

The present study focus on tackling the casting defect of aluminium A356 alloy, this alloys have very good casting and machining characteristics, which dominantly affects the part produced by identifying the major defects caused by existing gating system. The major objective of this study is to minimize casting defect of spare part manufactured in textile Share Company by using Pro CAST software. This study is conducted in Bahirdar textile foundry workshop, the casting parameters which highly contributes to the soundness casting are identified with basic metallurgical and foundry properties of aluminium A356 alloy. The development of gating system for aluminium alloy is done by following American foundry society standard for getting reliable results. The optimization of Ingate and riser of gating system is carried out by Taguchi Method. The analysis result reports the shrinkage (macro) porosities and hot spot defects under existing gating system practised in the factory. After identifying the porosity defect; results of analysis process are iterated to get the optimum results, porosity found to be minimized for various gating system parameters. From simulation result; it is found that the best suited gating system parameter for aluminium A356 alloy sand casting is tapered sprue in decreasing initiation of defect from scratch. Finally, it is recommended that the company should implement the optimized processes parameters in addition to taking remedial action on the influential factors of the casting process.

<sup>⊙</sup> Professor,

<sup>#</sup> Lecturer,

\*Corresponding author: Email: [skishor75@gmail.com](mailto:skishor75@gmail.com), [kishorkolhe05@gmail.com](mailto:kishorkolhe05@gmail.com);

*Keywords: Thermal solver; flow solver; Mesh CAST; Pre CAST; data CAST; pro CAST; simulation of casting process.*

## 1. INTRODUCTION

Presently; in Ethiopia the main focus of government is on establishment of large and small scale industries due to the large demand spare parts for handling machine parts and systems. Moreover, it becomes imperative to fulfil the needs of utensils, machine tool spare parts, auto parts, hand tools for local consumption and engineering applications. The widely applied manufacturing technology comprises the worth mentioning processes like; Machining, joining, forming, and founding ranging from traditional system to advanced manufacturing systems. Each of these manufacturing systems has their own contribution in the development and establishment of industrial setup in the country [1]. Moreover; Ethiopian industries are also using the above manufacturing processes to the extent of their technological and financial potentials to satisfy the domestic demand at most. The high cost importing goods, prolonged lead time higher exchange rate are some of the major challenges; that urges expansion of local firms. There are several local industries, which have to be competent enough to withstand the above challenge and able to penetrate the global market. In the Manufacturing market; like ease of fabrication, low cost and its versatility of operations make casting processes superlative [2]. For example, basic metals and engineering industry, like; Hormat engineering factory, Bahirdar textile Share Company, Kombolcha textile and Kaliti metal factory are using various casting processes for manufacturing of different tools and accessories. Foundry workshop of Bahir Dar Textile Factory was established with the aim of producing spare parts for its machines and to save the company from high cost [3]. However, sand casting is the process used to cast different types of machine parts in the textile factory work shop involves many casting processes parameters, that affect the quality of the castings produced. Aluminium and aluminium alloys are one of the most common nonferrous metal, which are used for making machine spare parts, that require high casting ability and wear resistance, such as Gear, Gear block, pulleys, textile housing etc. Scrapes and wasted aluminium parts are collected and used as a source of casting material for aluminium alloy [4]. Although; foundry work shop has a great role in producing spare parts, currently it is facing with

many defects that lead to wastes casting product, power and capital investment. Common defects observed for aluminium casting are gaseous cavities; like blow hole, pine hole, air inclusions, shrinkage cavities such as internal and external shrinkage and surface defects; like erosion, sand inclusion, scab, etc [5]. These defects ranged from the simple defects; which can be easily repaired up to severe defects that lead to rejection of the part. Gas porosity is one of the most serious problems especially in the castings of aluminium and aluminium alloy. It is generally caused by evolution of gases during the casting and solidification processes [6]. The gases may result from reaction between the casting sand or mold and the metal, or they may result from the evolution of gases dissolved in the liquid metal during solidification. In order to overcome and eliminate these defects, it is necessary first to get all pertinent data related to the production of the casting (sand and core properties, gating system, pouring temperature, etc.) and identify the defect correctly. Once the defect is identified, characteristics determined the possible causes and finally the remedies are attempted using the data for appropriate corrective action. Most of the previous studies have analysed and examined the relationship between sand mould characteristics and design conditions. They clearly indicated that the design of sand mould is vitally important to the processes of casting formation. However, the gating system and process parameter combinations play an important role for the quality of casting parts in addition to sand mould characteristics. *The Optimization design of a gating system for sand casting aluminium A356 using a Taguchi method and multi-objective culture-based QPSO algorithm by using response surface methodology to construct a second-order regression model, including filling time, solidification time and oxide ratio. The minimal filling time, minimal solidification time and minimal oxide ratio results obtained using the CBQPSO algorithm were reduced by 68.14%, 50.56% and 20.20%, respectively, compared with those of the initial model [7].*

Nowadays, there are available computer software's that successfully applied to simulate filling and solidification process of a cast product. The accurate result of simulation allows improved casting design along with the optimization of the gating and riser system that

helps to produce a sound cast product [8]. Casting simulation has become a powerful tool to visualize mould filling, solidification, cooling, and also to predict the location of internal defects; such as shrinkage porosity, sand inclusions, and cold shuts. It can also be used for troubleshooting existing castings, and for developing new castings without shop-floor trials. Software analysis and simulation of the casting process is found to be time saving, and economical. Moreover, flexibility and iterative analysis are only possible by the use of these software packages; this research study is going to answer the general problem to be stated in the sand casting process of the factory [9].

## **2. THEORY OF CASTING AND SIMULATION SOFTWARE**

### **2.1 Sand Casting Process**

Sand casting is still the most popular and reliable process for fabrication of heavy and unique cast product among the various casting processes [10-15]. The steps to make sand castings are illustrated in Fig. 1.

The various elements of a gating system for aluminum and its alloy sand casting process are depicted in Fig. 2.

### **2.2 Quality Problems in Sand Casting Process**

During the use of sand casting process for aluminum and its alloys, various defects are observed, that may results severe problems in the aluminum metal casting are illustrated in Fig. 3. Also, it is very important to improve the casting quality of aluminum cast product by eliminating or minimizing the effects caused by those defects. Some of common defects noted are, blow or blowhole, a shrink or shrinkage cavity, a rat tail, buckle, hot tear and scab etc, all these defects originate in the cast product when pouring of molten metal in the pouring basin of sprue cavity is interrupted, so that the metal does not properly fuse together in the sprue cavity, results in the formation of defects in the final cast product [5, 6].

### **2.3 Pro-Cast simulation Technique for Casting Defects Analysis**

Pro-cast simulation is the physical process of emulating a real phenomenon using a set of

mathematical equations implemented in a computer program. In casting simulation, the mould filling and solidification analysis are to be done by using an algorithm or program based on finite volume method. The simulation programs are based on finite element analysis of 3D models of castings and user interface computation and display. The casting model (with feeders and gates) has to be created using a solid modeling system that imported into the simulation program. It is based on a coupled finite element methodology with a volume of fluid technique for the computation of mold filling. A typical casting is produced by pouring liquid metal into a suitably prepared mold cavity containing the topology of the part to be manufactured. Result of energy extraction through the mold walls, the liquid metal cools and solidifies producing a consolidated metal part. The soundness and overall quality of cast metal part is strongly affected by the details of the liquid metal flow during mold filling and of the time dependent temperature during solidification. Macro and microstructural characteristics of the cast parts are determined by the flow and thermal history of the casting processes, and these in turn used to determine the mechanical and other physical properties of the material. The basic operation of the Pro-Cast simulation technique for casting defects analysis of aluminium and its alloys are reliable and straight forward. The key modules reported in the available literature for casting defect analysis are called Mesh CAST, Pre CAST, Pro CAST and Visual CAST, also these Pro-cast simulation software finds application in design and developments of Agricultural tools and machineries [16-22].

### **2.4 Evaluation of existing Process and defect analysis at Bahir Dar Textile Company**

- i) Casting Process Practiced in Textile Share Company: Sand casting is the most common and ideal process adopted in global manufacturing industries, which is also used in foundry section of Textile Share Company, for getting economical, quality and customer focus heavy unique cast products.
- ii) The mould material and the preparation: Green sand molding is used for all categories of metal and its alloys. The mixing of the mold ingredients are carried

out in the Muller. The proportion of the ingredient; like clay, moisture and sand are done with trial and error without any specific measurement and knowledge. The efficiency of the Muller is not capable of mixing in good proportion due to the long-time usage. Hence; the fertility faced in the mixing of ingredients are the major source of the mold related defects.

### 3. MATERIALS AND METHODS

#### 3.1 Method

This research work mainly focuses on optimization and development of gating system for bringing more soundness of the casting products in Bahir dar textile Share Company, in details of mould preparation and sand preparation method are shown in Fig.4.

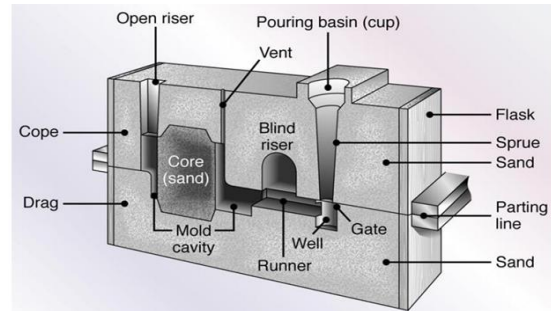
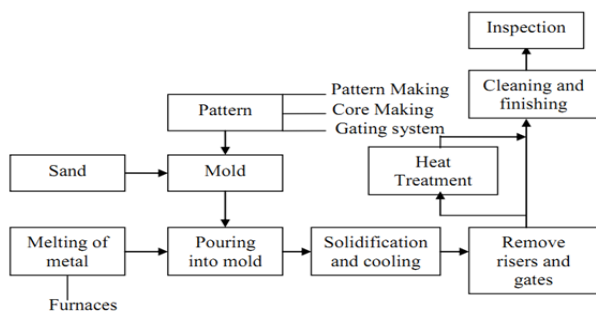

Fig. 1. Production steps in a typical sand casting process.

Fig. 2. Element of gating system in sand casting process

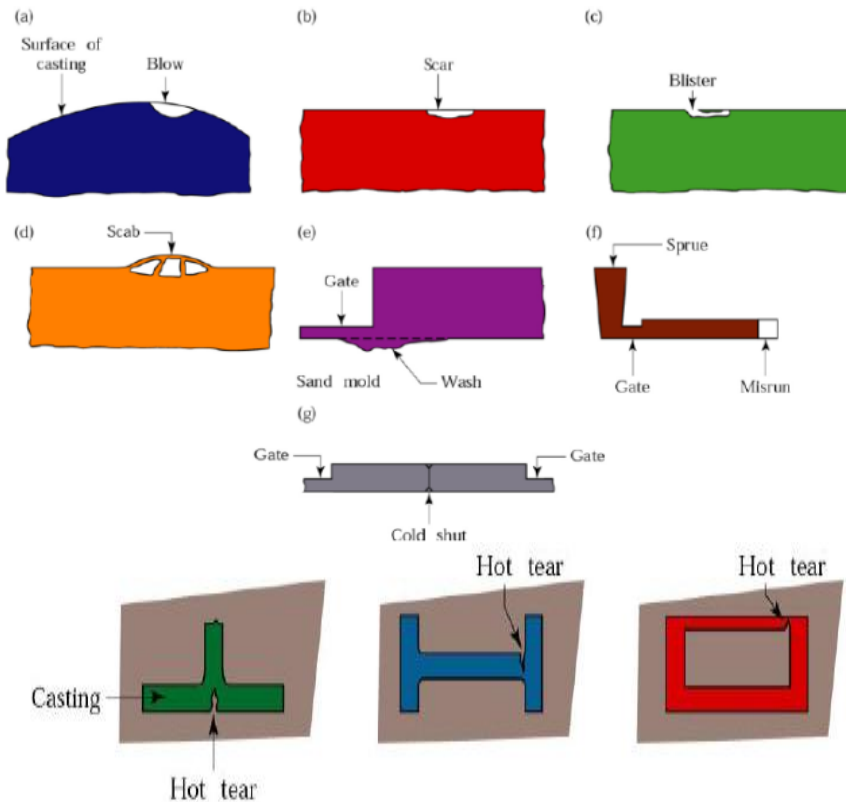
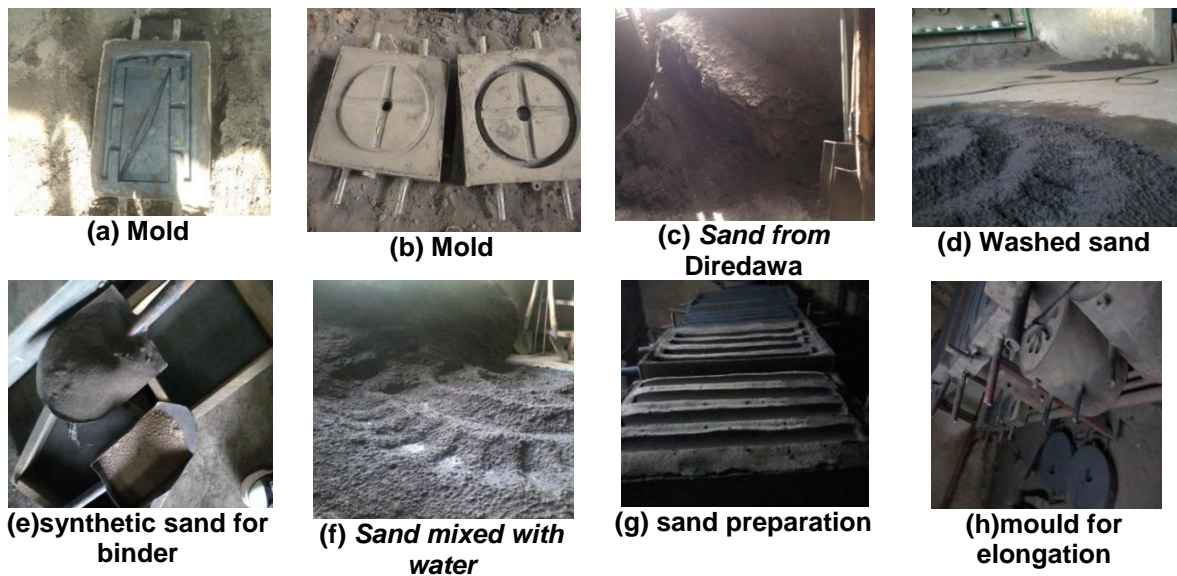

Fig. 3. Defects observed in aluminium and it alloys by using sand casting process



**Fig. 4. (a-h) Mold and sand preparation methods for molten metals pouring**

The detail method of analysis used in this research is adopted to get better efficient design and software application. The following steps are adopted for the mould and sand preparation;

1) Data collection and organization: the brief details of the adopted sources are as given below;

- ✓ Primary data gathering techniques: an individual experience, real practical observations in the manufacturing organization.
  - ✓ Secondary data gathering techniques - documentation from factory, standards on the particular process and materials used from, Foundry Design handbooks, Material handbooks, and internet website etc.
- 2) Review of literature from the scientific literature to add more values to the present development work with scientific and technical justifications.
- 3) Problem formulation and analysis. This is to be done in the following stepwise approach.
- ✓ Conduct assessment of casting process in particular sand casting process, of which the major casting defects are prevailing.
  - ✓ Identification of the most severe casting defects for selected casting alloys.
  - ✓ Study focuses on possible casting related factors and establish causal relationships.

- ✓ Determine the most serious causes and the required analysis to be conducted.
- ✓ Discussion of casting process principles and mathematical model are conducted to the substantive analysis and simulation.
- ✓ Conduct the analysis using simulation software Pro-CAST 2013 for optimization of the casting process parameters.

#### **Problems observed in Existing Gating System:**

A key element in producing quality aluminum and its alloys castings is the proper design and sizing of the gating and riser systems. In Bahir dar textile foundry the same kind of gating was used for all metal types as well as for different sizes of the part this causes shrinkage, porosity and in complete filling type of defects in a cast product. Aluminum alloys has different metallurgical property compared to other metals, so the gating and riser practices needed for aluminum alloys are also different from the other metals. Therefore in the present research work an available textile housing spare part is used to illustrate the optimization process, its current gating system is shown in Fig. 5. Many of the defect incurred in the textile housing spare part shows an error of gating system design that is why, present study emphasis more detail on the gating system, which consists of sprue, runner, in gate and riser as a main influencing parameters.

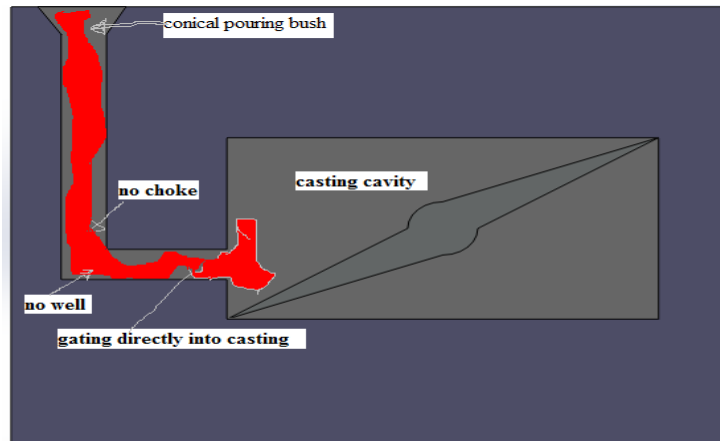

Fig. 5. Traditional Gating system design used in the textile foundry

### 3.2 Aluminium A356 Defect analysis

The overall casting defect analysis of the textile foundry part is planned as shown in Fishbone diagram in Fig 6. For getting the defect free casting, the proposed sand casting for Aluminium 356 alloy thoroughly studied. The sand property such, as sand grain like shape, type and size, mould properties like, moisture %, clay content and mould hardness properties were analysed. Also, aluminium metal condition, like composition, fluidity and pouring temperature. And a gating design like riser design, pouring time and runner design.

**Experimental procedure:** The experimental procedure is mainly divided into three stages as; Simulation Preparation, Computer Aided Simulation on Pro-CAST, and analysis. The overall flow chart of simulation work on Pro cast is depicted in Fig. 7.

The proposed design of Textile housing with gating system element is depicted in Fig. 8.

Gating ratio practiced for proposed aluminium casting of Sprue: runner: Ingate is 1:4:4 was considered, and sprue exit cross sectional area used in textile foundry, is selected 600 mm<sup>2</sup>. However, the runner cross section is calculated by using following relation as shown by equation 1.;

$$\frac{A_s}{A_r} = \frac{1}{6}$$

$$A_r = 600 * 4 = 2400mm^2 \quad (1)$$

Where,  $A_s$  = cross sectional area of the sprue at the exit. Hence diameter of the sprue at the exit

can be easily calculated. From cylindrical shape of the sprue, using the circular area formula the junction ( $D_{ex}$ ), is calculated as presented in equation 2:

$$D_{ex} = \sqrt{4 \left( \frac{A_s}{\pi} \right)}$$

$$D_{ex} = \sqrt{4 \left( \frac{600}{\pi} \right)} = 27.64mm \text{ or } 2.764cm \quad (2)$$

Sprue should be tapered by approximately 5 per cent minimum to avoid aspiration of the air and free fall of the metal. The practically used sprue that sprue cross section at the pouring basin is minimum 17 Per cent greater than the cross section of the sprue. Therefore, the inter diameter, from monograph of aluminium we get the sprue top area is 800 mm<sup>2</sup>.

$$D_{in} = D_{ex} = \sqrt{4 \left( \frac{800}{\pi} \right)} = 31.97mm.. \quad (3)$$

Similarly, the cross sectional of Ingate,  $A_i$  is

$$\frac{A_r}{A_i} = \frac{4}{4} \quad (4)$$

So area of Ingate  $A_i = 2400 mm^2$

### 3.3 Optimization of Ingate and Riser by Taguchi Method

Taguchi method was used to harmonize the parameter, the number of factors to be consider for the proposed design were sprue shape

(parallel and tapered), number of runner (one and two) and number of Ingate (three and four). An experiments are conducted with with 3 parameters and 3 levels of each parameter using

orthogonal array as shown in Table 1. The optimization of riser is carried out by using Chvorinov principle, the optimized model of riser is as shown in Fig. 8 (a,b).

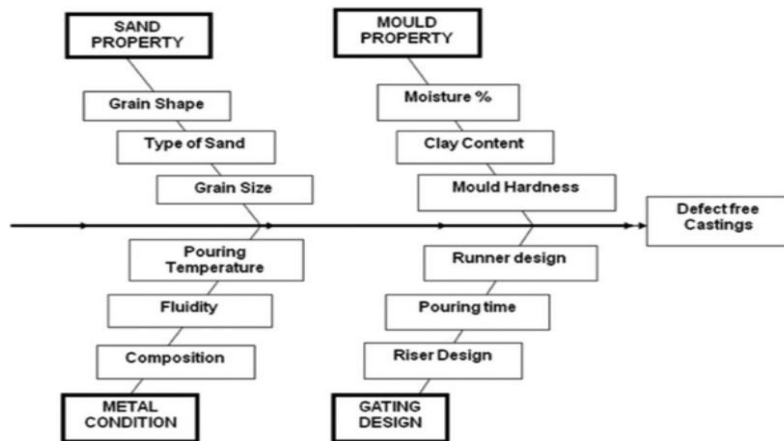

Fig. 6. Fishbone diagram of aluminium a356 defect analysis

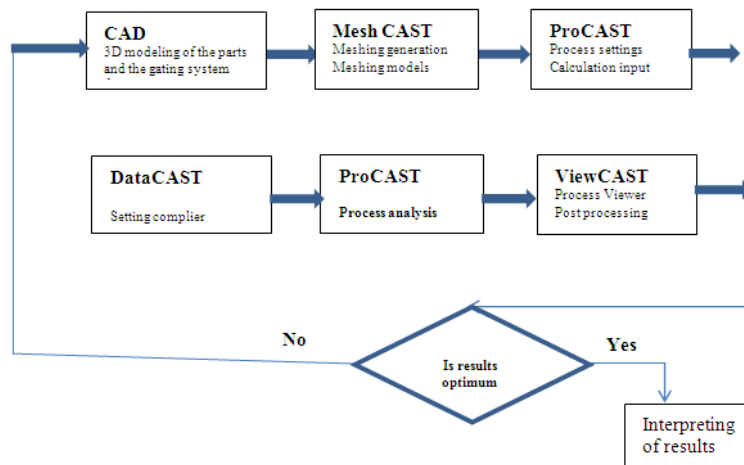
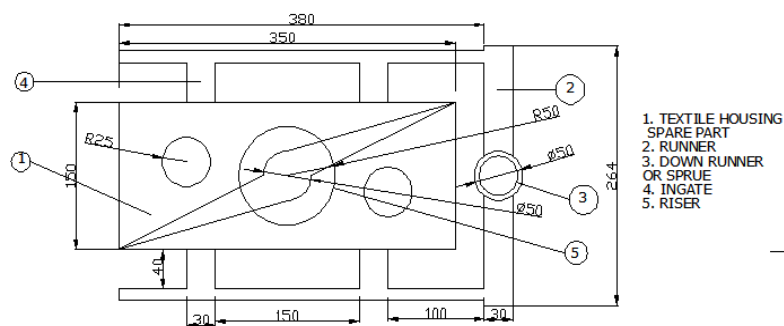
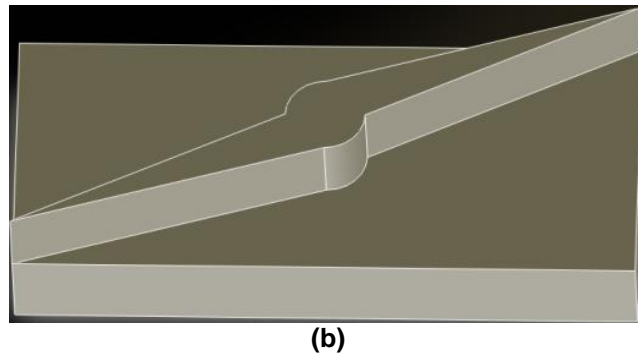

Fig. 7. Flow chart of simulation work on Pro-CAST



(a)



**Fig. 8. (a,b) The proposed design of Gating system**

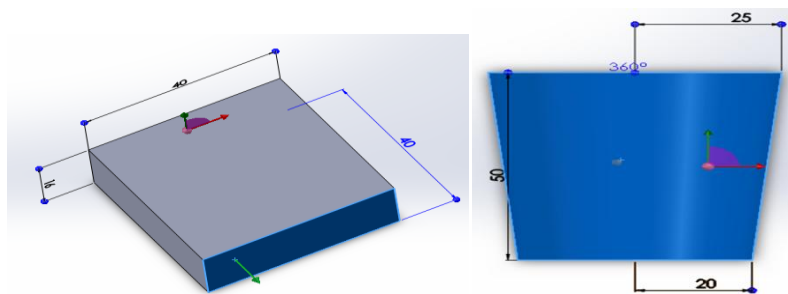

**Fig. 9. (a,b) Optimization of Ingate and Riser**

Table 1, Presents the parameter developed for checking the optimum value of riser by considering different models by keeping riser radius constant for three models as 35,30 and 25 mm for observing the height and number of riser.

#### 4. RESULTS AND DISCUSSION

The results of the percentage of shrinkage verses the numbers of models and hotspot with the number of model are presented in Fig. 10 (a, b).

Fig. 10 (a), presents the simulation results of Ingate Optimization with the influence of *per cent* shrinkage with number of simulation models and

Fig. 10 (b) represents the results of Influence of optimization parameter with hotspot defects.

Fig. 12 (a,b) depicts the first phase optimization the value of shrinkage porosity is decreased from 60 % to 40 %. In the second phase optimization the value of shrinkage remain the same the first optimization. In the third phase optimizations the value of shrinkage decreased with the riser used. The value of shrinkage are mainly depends on the riser shape and number of riser used. Also; Fig. 13 depicts the results of hotspot in second on the respective model no, however the optimised severity of hotspot obtained from 36 second to 254 seconds, this shows that the optimization of gating system have direct relationships with hot spot defects.

**Table 1. Parameter developed for checking optimum value of riser parameter**

Number of model	Radius of riser (R)	Height riser (HR)	Number of riser(NR)
1	35	40	1
2	35	50	2
3	35	60	3
4	30	40	2
5	30	50	3
6	30	60	1
7	25	40	3
8	25	50	1
9	25	60	2



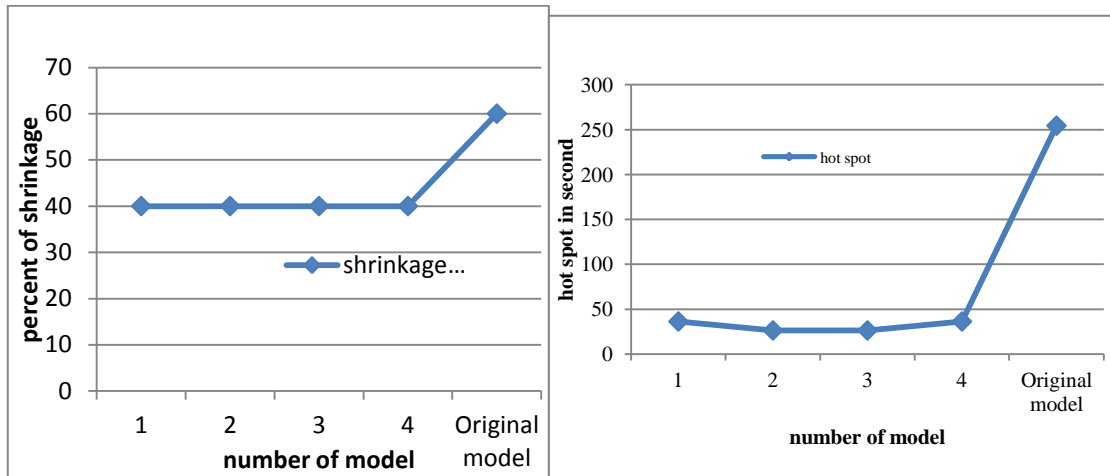

Fig. 10 (a, b) Result of runner optimization for shrinkage porosity and hospot runner

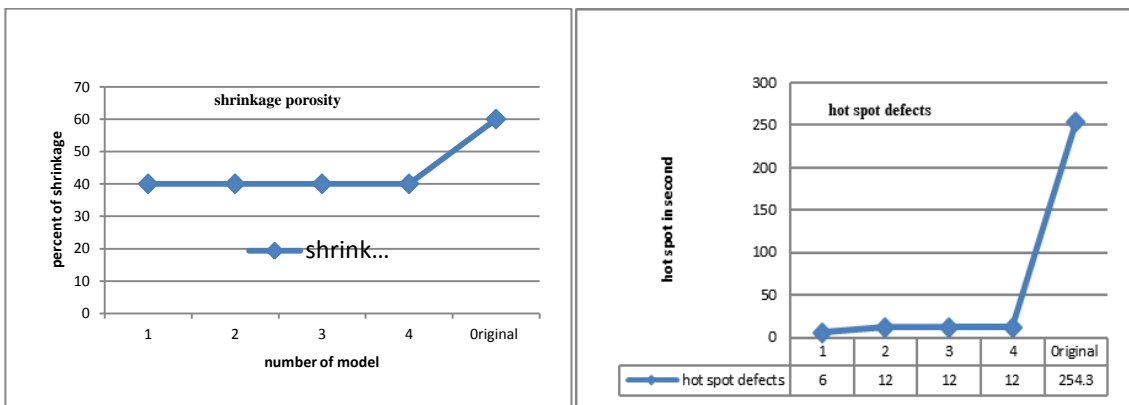

Fig. 11 (a,b). Simulation result of Ingate optimization parameter with shrinkage porosity

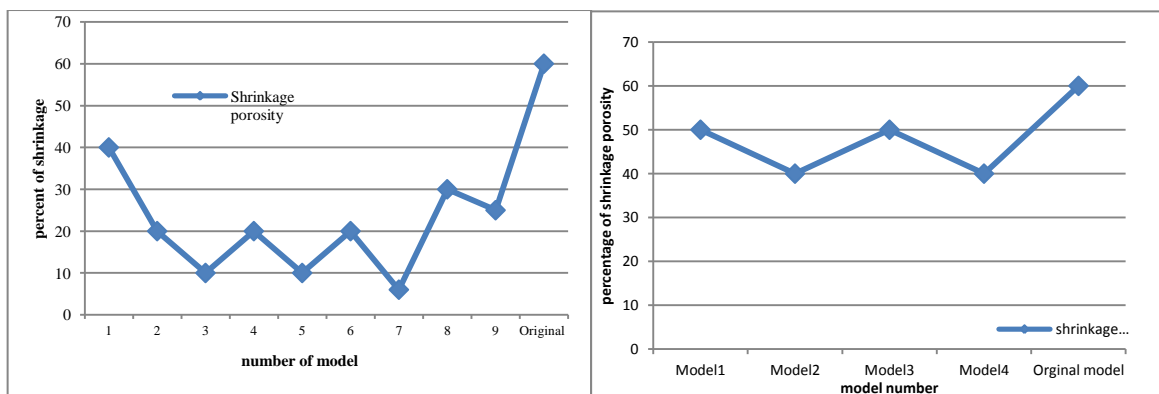

Fig.12 (a,b). Results of Shrinkage Porosity on number of models and first phase optimization

In order to minimize the entrapment of air in aluminium, the mould erosion, the best gating system would be a multi ingate with a central sprue, a rapid filling, low velocity system of properly proportioned runners and gates and short sprues with an enlarged well base. Fig. 14

(a,b) the result of simulation shows that using multi ingate the hot spot are reduced from 254 sec to 10 sec. This shows that the optimization of gating system have direct relationships with hot spot defects. However; the shrinkage porosity decreased only by 20 per cent from the original,

but its dispersed are decreased. These simulation result shows there is further optimization of gating element may be rises. Because the optimized gating element and shrinkage porosity has no more relation as optimisation simulation figure shows Voids decreased from dispersed area to small area of the cast part. In first case the void defects are dispersed with high volume of because of using cylindrical parallel sprue. So using tapered sprue the entrapment of the air during pouring causes voids defects these are decreased with tapered sprue.

#### 4.1 Simulation Models

From the simulation models it is observed that *per cent* of shrinkage porosity is not influence with optimization of runner and hot spot. Fig. 15, present the models that are very affected part by

shrinkage and porosity with large distribution of porosity. Because all design are within shop floor are on trial and error and there was no consideration of the standard parameters. In existing gating system the value of shrinkage are around 60 % with highly dispersed area on the casting surfaces. In first phase optimization the value of shrinkage porosity is decreased from 60 % to 40 %. In the second phase optimization the value of shrinkage remain the same the first optimization. In the third phase optimizations the value of shrinkage decreased with the riser used. The value of shrinkage are mainly depends on the riser shape and number of riser used. Using three riser with R=25 mm, HR= 40, and the value of shrinkage porosity decreased from 40 % to 6 %. These optimizations values of shrinkage are noted, because the shrinkage porosity has direct relations with number of riser and size of riser.

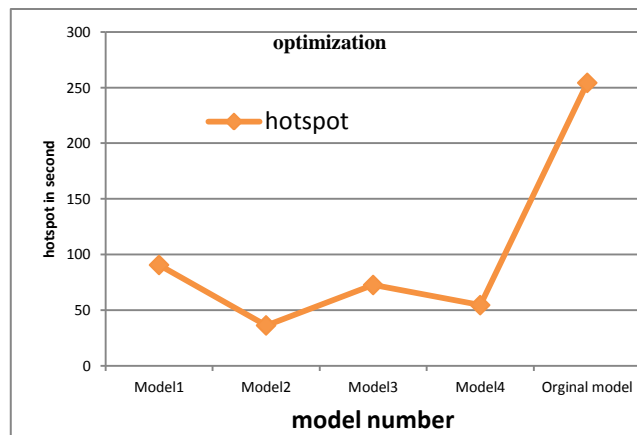

Fig. 13. Results of Hotspot on model number optimization

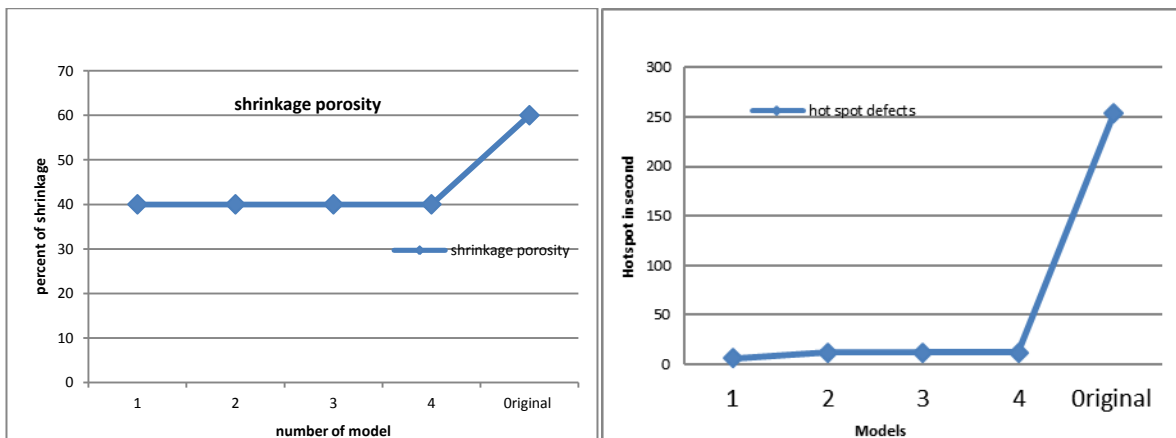

Fig. 14 (a,b). Simulation result of ingate optimization parameter with shrinkage porosity

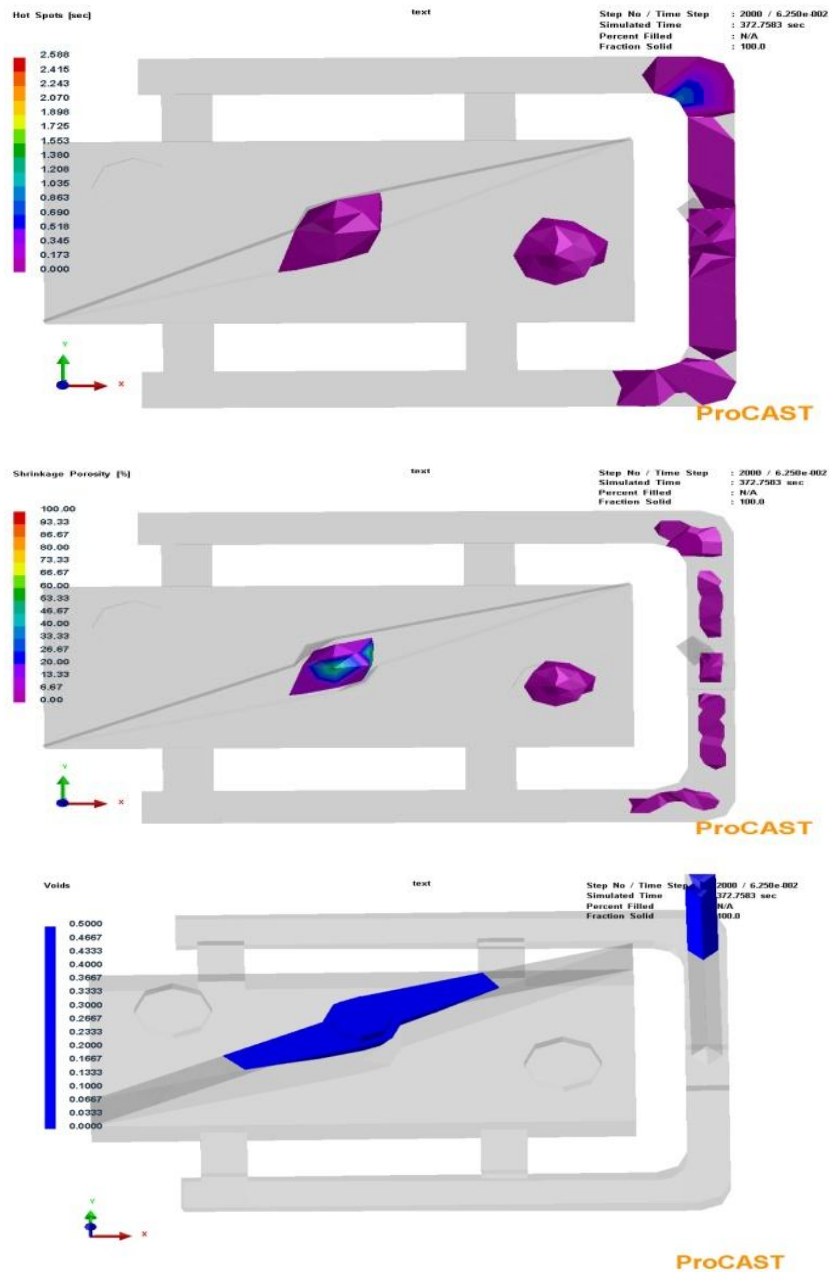

Fig. 15 (a,b,c). Results Simulation models of Pro-Cast software

It is observed also observed from the simulation models that the amount of hot spots observed to be high. However to reduce this defect several possibilities exist for gating system design and foundry engineers have to select, which design is available for quality casting system. The simulation provides use full information's to help position and dimension the gating system. Important design decisions can therefore be taken an early stage with simple value of parameter.

## 5. CONCLUSIONS

It can be concluded from this study that simulation helps to visualize filling and solidification phenomena with no wastage of time, energy, labor and money. Hence casting simulation enables to provide 'correct at the first time' through preventing potential problems related to flow of metals or during the time of freezing compatible with both product requirements and foundry capability for the

casting aluminum and its alloys using sand casting.

The optimization of gating system for aluminium sand casting was performed by several design parameters like; shape, position, geometry, and gating ratio of the parameter. Also these designs parameters are checked and verified by ProCAST 2013 casting simulation software. The simulation reveals that the optimum parameters for aluminium sand casting are four ingate and two runners are used with appropriate position or from both side of casting and tapered sprue used with appropriate position are used in defect minimization.

Totally changing the existing gating system element and redesigning parameters the defect in the component to be cast has obtained defect free. Using redesigned and optimized value of gating element parameter hot spot defects are decreased from 254.3 second to 6 second.

In the existing practiced gating parameter the porosities and hot spot are dispersed over the surface of the casting and also more than 60 % shrinkage porosities are located from simulation results. After optimising design of gating parameter the porosities are located at the gating system element which is removed from casting after solidification, so these mean casting parts are not affected, also even if porosities are located on gating element it decreased to less than 6% in availability.

## ACKNOWLEDGEMENTS

The authors of this paper like to thanks to Bahir Dar University and Bahir Dar Textile industry for their moral support during this research work.

## COMPETING INTERESTS

Authors have declared that no competing interests exist.

## REFERENCES

1. John Campbell: A Text book 'The New Metallurgy of Cast Metal Castings, Second edition', University of Birmingham, UK; 2003.
2. ASM Hand Book, Volume 15 ASM International, The Material Information Company, March; 1998.
3. Peter Beeley BMet, PhD, DMet, A Text book on "Foundry technology", British Library Cataloguing in Publication Data, 2<sup>nd</sup> Edition University of Leeds; 2001.
4. Kolhe KP, Hingole RS. A Text book on Elements of Casting Technology", LAP LAMBERT Academic Publishing, Germany; 2017.
5. Ravi B. A Text book on Metal Casting: Computer-Aided Design and Analysis" Prentice-Hall, New Delhi, India; 2005.
6. Wen-Jong C, Cai-Xuan L, Yan-Ting C. Jia-Ru L. "Optimization design of a gating system for sand casting aluminium A356 using a Taguchi method and multi-objective culture-based QPSO algorithm" Advances in Mechanical Engineering. 2016;8(4):1-14.
7. Behera R, Kayal S, Sutradhar G. Solidification behaviour and detection of Hotspots in Aluminium Alloy castings: Computer Aided Analysis and experimental validation" International Journal of Applied Engineering Research, Dindigul. 2011;1(4):715-726.
8. Ravi B, Srinivasant MN. Casting solidification analysis by modulus vector method, International Journal of Cast Metals Research. 1996;6(1):1-7.
9. Blair M, Raymond WM, Christophe B. 'The Effect of Pour Time and Head Height on Air Entrainment', University of Iowa. Proceeding of 48<sup>th</sup> SFSa Technical and operating conference Paper no 1.11, steel founder society of America, Chicago, IL; 1993.
10. Ravi B. intelligent design of gating channels for castings, Materials science and Technology. 2013;13(9):785-790.
11. Shamasundar S, Damayanthi, Ramachandran, Shrinivasan NS, Manjunatha TM. Computer Simulation and Analysis of Investment Casting Process.
12. Campbell J. The ten castings rules guidelines for the reliable production of reliable castings: A draft process specification," Materials Solutions Conference on Aluminum Casting Technology, Chicago; 1998.
13. Green NR. J. Campbell, Influence of oxide film filling defects on the strength of aluminium alloy Al 7Si-Mg alloy castings, Transactions of the AFS, (1994).
14. Pro CAST User Manual & Technical Reference; 1998-2013.

15. Liu F. Optimized Design of Gating/Riser System in Casting Based on CAD and Simulation Technology; 2008.
16. Kolhe KP, Datta CK. Prediction of Microstructure and Mechanical Properties of Multipass SAW” Journal of Material Processing Technology. 2007;197(1-3): 241- 249.
17. Kolhe KP. Testing of Tractor Mounted and Self Propelled Coconut Climber for coconut harvestings. World Journal of Engineering. 2015;12 (4):399-406.
18. Kolhe KP. Testing of Tractor Mounted Hydraulic Elevator by using Digital Load Shell. World Journal of Engineering. 2015;12 (5):479-488.
19. Kolhe KP. Mechanized harvesting device A need of Coconut growers in India. Indian coconut journal, published by Ministry of Agriculture, CDB board Kochi Kerla. 2010;73(2):15-19.
20. Kolhe KP. Development and testing of tree climbing and harvesting device for mango and coconut trees. Indian coconut Journal, Published by Ministry of Agriculture, CDB board Kochi Kerla. 2009;52(3):15-19.
21. Kolhe KP. Stability analysis of tractor mounted hydraulic elevator for horticultural orchards. World Journal of Engineering. 2015;12 (5):479-488.
22. Kolhe KP, Jadhav BB. Testing and Performance Evaluation of Tractor Mounted Hydraulic Elevator for Mango Orchard. American Journal of Engineering and applied sciences. 2011’4(1):179-186.

© 2022 Kolhe and Gebrekidan; This is an Open Access article distributed under the terms of the Creative Commons Attribution License (<http://creativecommons.org/licenses/by/4.0>), which permits unrestricted use, distribution, and reproduction in any medium, provided the original work is properly cited.

*Peer-review history:*

*The peer review history for this paper can be accessed here:  
<https://www.sdiarticle5.com/review-history/86614>*